



# Voltage Recorder RVR-52A

## Wireless Data Logger for Voltage / Pulse / Event Time / Soil Moisture

### User's Manual

Thank you for purchasing this product. Carefully read and fully understand these instructions before using this unit.

Inquiries

## T&D CORPORATION

5652-169 Sasaga Matsumoto City NAGANO 399-0033 JAPAN  
Tel: +81-263-27-2131 Fax: +81-263-26-4281  
E-mail: overseas@tannd.com.jp  
Homepage: http://www.tannd.com/

## T&D CORPORATION

© Copyright 2001-2005 T&D Corporation. All rights reserved.  
2005.09 16004335080

This is printed on 100% recycled paper.

### Specifications

Measurement Channels	1 Channel (Select from: Voltage / Pulse / Event Time / Soil Moisture)
Voltage	Input Voltage Range: 0 to 6.5V
	Measurement Resolution: 1mV
	Measurement Accuracy: ± 0.5% +5dgt. (at 0 to 40°C)
	Input Impedance: Approx. 1M Ω
Pulse	Input Voltage Range: 0 to 30V
	Detection Voltage: Lo: below 0.6V/Hi: above 2V
	Response Time: 30Hz/Approx. 15 msec or more (over 2.5V)
	Response Polarity: Select Lo → Hi or Hi → Lo
	Highest No. of Counts: 32000
Event	Input Impedance: Pull-up Resistor Approx. 100k Ω
	Input Voltage Range: 0 to 30V
	Measurement Resolution: 1 sec
	Detection Voltage: Lo: below 0.6V/Hi: above 2V
	Response Time: 1 sec
Recording Interval	Response Polarity: Both Lo → Hi and Hi → Lo
	Input Impedance: Pull-up Resistor Approx. 100k Ω
	Recording Interval: 1,2,5,10,15,20,30 seconds, 1,2,5,10,15,20,30,60, minutes
	Total of 15 choices (Excluding Event data)
	Recording Capacity: Voltage / Pulse / Moisture:16,000 Readings · Event:8,000 Readings
	Recording Mode: Endless / One-time
	LCD Display Items: Current Readings · Recording Settings · Battery Life Warning · Over Measurement Range Warning · Unit
	Power: Lithium Battery (LS14250(SAFT)) × 1 or AC Adaptor (sold separately)
	Battery Life: Approx. 6 months / Approx. 2.5years with RTR-05B1 (Battery life depending on measurement environment, recording interval and battery performance)
	Wireless Method: FCC:Part 15 Section 249 / IC:RSS-210
Transmission Distance: Up to 100 meters (330ft) May vary with conditions	
Interface: Wireless Communication (RTR-57U) / Optical Communication (RTR-57U, TR-50C)	
Communication Speed: When downloading data (Wireless) Approx. 2,000 readings per minute [Collection of a full unit of data=Approx. 420 seconds (optical communication=Approx. 160 seconds)]	
Water Resistance ※ 1: IP64 (rated for use in daily life) ※ 2	
Pre-heat time: 50msec or 1 ~ 10 sec (steps of 1 sec.)	
Dimensions: H62 x W47 x D19mm (excluding protrusions / antenna length 20mm) / with Large Capacity Battery Pack: D50mm	
Weight: Approx. 56g. (including 1 lithium battery) / with Large Capacity Battery Pack : Approx. 109g	
Unit Temp. Resistance: - 40°C to 80°C ※ 3	
Standard Input Cable: RPR-7101 (ength: Approx. 1.5 m) × 1	
Accessories Included: Lithium Battery (LS14250 (SAFT)) × 1 · Tube × 1, Strap × 1 · User's Manual (Warranty) × 1	

※ 1: Not for continued immersion.  
※ 2: Note: The water resistance rating with the sensor or input cable connected is IP64.  
※ 3: Radio communication can not be operated at -30 degrees or less.

### Notices about this User's Manual

- Please read this manual carefully before using the product.
- All rights of this User's Manual belong to T&D Corporation. It is prohibited to use, duplicate and/or arrange a part or whole of this User's Manual without the permission of T&D Corporation.
- Please follow the safety precautions carefully. We cannot guarantee nor are we responsible for safety if this product is used in any manner other than was intended.
- T&D Corporation accepts no responsibility for any malfunction of and/or trouble with this product or with your computer that is caused by the improper handling of this product and will deem such trouble or malfunction as falling outside the conditions for free repair of the attached warranty.
- T&D Corporation accepts no responsibility for any result or effects from using this User's Manual.
- Figures and illustrations in this manual may be slightly simplified and may differ from the actual product.
- On screen messages, figures or illustrations in this manual may vary slightly or be simplified from the actual messages and product.
- We sincerely hope that the contents of this manual are true and complete. If you find any information to have been omitted, or if the information within is confusing or mistaken please, contact your retailer or T&D Corporation.
- Microsoft®, Windows® and WindowsNT® are registered trademarks of Microsoft Corporation USA and are binding in the USA and all other countries. Company names and product names are trademarks or registered trademarks of each company.
- This User's Manual cannot be reissued, so please keep it in a safe place.
- Please carefully read this User's Manual and Warranty.

### Safety Precautions and Instructions

Please carefully observe the following safety measures when using our product. To prevent any loss or damage to our customers, other people and/or property, and to ensure the proper use of our products we ask that before using our product you carefully read, understand and follow the safety rules and precautions for our products as outlined below.

#### Explanation of Warning Symbols

- These entries are actions that absolutely under no circumstance should be taken. The taking of such an action may cause serious personal physical damage or death.
- These entries are actions that if taken may lead to physical injury or damage to persons or things.

#### Explanation of Picture Symbols

- This symbol denotes an important warning or caution. Inside or near the symbol will appear another symbol giving details. (EX: stands for ELECTROCUTION)
- This symbol denotes a forbidden action. Inside or near the symbol will appear another symbol giving details. (EX: stands for DO NOT TAKE APART)
- This symbol denotes an action that you must take. Inside or near the symbol will appear another symbol giving details. (EX: stands for TAKE PLUG OUT OF SOCKET)

## About Voltage Recorder RVR-52A

Our RVR-52A not only measures and records voltage, pulse, event, and soil moisture data, but enables you to send this data via wireless radio communication to an RTR-57U Data Collector where it can be downloaded, processed and analyzed. Beyond the gathering of data, the RTR-57U gives you the power to start and stop logger recording, check data, and monitor current readings from a distance. Besides wireless communication, optical communication is also possible.

### Basic Functions

#### [Wireless Communication Function]

The data recorded with the RVR-52A can easily be downloaded via wireless radio communication to a RTR-57U Data Collector, where the data can be saved for later download to your computer. Moreover, all recording settings, settings changes and recording start and stop can be controlled via wireless communication.

Note: In order to collect data via wireless communication, it is necessary to register via computer the RVR-52A unit as a Remote Unit in the RTR-57U unit you wish to use. For details about making these settings, please see the Help Menu in [T&D Recorder for Windows US] or the User's Manual for [T&D Recorder for Windows US].

#### Gathering Data via Wireless Communication

The wireless communication range, if unobstructed and direct, is about 100 meters.

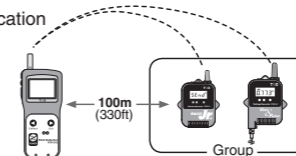

Connect your computer to the RTR-57U unit and simply place an RVR-52A unit face down on an RTR-57U to carry out direct optical communication with your computer.

#### Example of Downloading Data via Optical Communication



#### [Pulse Measurement: 30 Counts per Second]

RVR-52A can measure up to 30 counts (30Hz) per second when the input voltage range is between 0-30V and there is a continuous pulse of more than 15 milliseconds. When measuring pulse, the largest number of counts for one recording interval is 32,000 counts. You can select from rising signal (Lo-Hi) or falling signal (Hi-Lo) and count when one or the other occurs.

#### [Voltage Measurement Range: 0-6.5V]

RVR-52A can measure and record input voltage from 0 to 6.5V. You can choose to record the voltage measurement as the instantaneous value for each recording interval span or as the average value for each recording interval span. The average value for recording intervals under 15 seconds will be calculated as the average of the measurements from every 1 second. The average for intervals over 20 seconds will be calculated as the average of the measurements from every 2 seconds.

#### [Event Time Recording]

RVR-52A can record the time of any event; a rising (Lo to Hi) or falling (Hi to Lo) waveform that occurs for more than 1 second at an input voltage range of between 0-30V.

#### [Recorded Data Capacity: 16,000 Readings]

Calculation Example :  
30sec (recording interval) × 16,000 readings (capacity limit)  
= 480,000 seconds = about 5 days and 13 hours.

Recording Interval	1 second	30 seconds	15 minutes	60 minutes
Time period	4 hours 26 min.	5 days 13 hours	166 days 16 hours	1 year 10 months

#### [Recording Condition Settings]

Settings such as Recording Mode, Recording Interval, Programmed Start Time, Immediate Start, and Measurement Contents (Voltage / Pulse) can be easily made via an RTR-57U unit or by computer.

Note: By starting a new recording session, all previously recorded data will be erased from the main unit. If you wish to save the data, make sure to download it to an RTR-57U unit or to your computer before beginning a new recording session.

#### [Downloading Recorded Data (Data Collection)]

Data downloaded to your computer can be processed into graphs, lists, saved to files, changed to text file, and printed out.

#### [Setting Upper and Lower Limits]

By setting upper and lower limits, a check will occur for data exceeding those limits each time data is downloaded to an RTR-57U unit.

### DANGER

- Do not take apart, repair or modify the main unit. It may cause fire, electrocution or damage. Ask the shop where you purchased the products or T&D Corporation to carry out any repairs.
- If any smoke or strange smells are emitted from the unit, immediately cease using it. Continued use may cause fire, electrocution or damage.
- Do not use any batteries other than those that are recommended. It may cause fire or damage.
- Do not use the input cable if it has water droplets or if your hands are wet. It may cause electric shock.
- If water or a foreign body enters the case, immediately cease using it.
- Store all batteries, sensors and Data Logger units out of the reach of children. It is dangerous to swallow batteries.
- Please be careful when you using in overly hot or cold environments, touching the units may cause burns or frostbite.
- RVR-52A has been designed to measure voltage and pulse. Do not use it for any other purpose than to measure pulse and voltage.

### Wireless Regulations

#### Radio, EMC and Safety Regulations

This device complies with part 15 of the Federal Communications Commission (FCC) rules and with RSS-210 of the Industry Canada (IC). Operation is subject to the following conditions:  
(1) This device may not cause harmful interference, and  
(2) This device must accept any interference received, including interference that may cause undesired operation.

Note: This equipment has been tested and found to comply with the limits for a Class A digital device, pursuant to part 15 of the FCC Rules. These limits are designed to provide reasonable protection against harmful interference when the equipment is operated in a commercial environment. This equipment generates, uses, and can radiate radio frequency energy and, if not installed and used in accordance with the instruction manual, may cause harmful interference to radio communications. Operation of this equipment in a residential area is likely to cause harmful interference in which case the user will be required to correct the interference at his own expense.

### CAUTION

- We are not responsible for any malfunction or trouble caused by the use of our product or by any problem caused by the malfunction of our unit. Please be fully aware of this before using our product.
- This product has been designed for private or industrial use only. It is not for use in situations where strict safety precautions are necessary such as in connection with medical equipment whether directly or indirectly.
- Operate the units with the latest version of [T&D Recorder for Windows® (US)]. The latest version software can be downloaded from our home page.
- This product is designed to measure voltage up to +6.5V at a voltage input of up to +30V. If used at a high voltage, such as AC100V, the signal production element and/or the product may be damaged.
- Do not drop or expose the unit to strong impact.
- Do not place any foreign objects in the input cable jack.
- Battery life depends on the measurement environment, communication frequency, recording interval and battery quality.
- Battery terminals may provide insufficient contact due to age or vibration. Please be careful not to lose data due to insufficient contact.
- The main unit when connected to the input jack is splash proof. Without the input cable connected the unit is not waterproof, so please do not allow it to become wet.
- Remove batteries from any unit that is not to be used for a long period of time. Batteries left in a unit not being used for a long time may leak and cause a malfunction.
- Pay attention to water leakage or foreign objects entering into the unit case as in the following cases.
  - The case was closed with dust, hair, etc., on the rubber packing or in the groove of the packing.
  - The rubber packing becomes damaged. (In this case, please purchase the optional maintenance set.)
  - The unit suffered from significant temperature change while wet. Especially if the temperature change is from high to low.
- Do not use or store the unit in places such as listed below:
  - It may cause electrocution, fire or damage to the unit or to your computer.
  - Areas exposed to direct sunlight
  - Areas exposed to water or high-pressure water flow.
  - Areas exposed to organic solvents and corrosive gas.
  - Areas exposed to strong magnetic fields
  - Areas exposed to static electricity.
  - Areas exposed to fire or overheating.
  - Areas exposed to excessive dust or smoke.

## Before Using

### ◆ Insert the batteries

Note:

- When changing batteries make sure to carefully read [Changing Batteries].
- Make sure no water gets inside the case.

1. Remove the screws and take off the back case.
2. Insert the battery in its tube and place in unit as in diagram.
3. Check the rubber packing for any cuts or scratches and replace the cover as it was when opened.

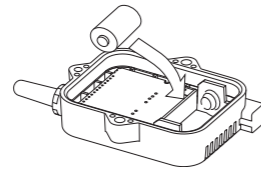
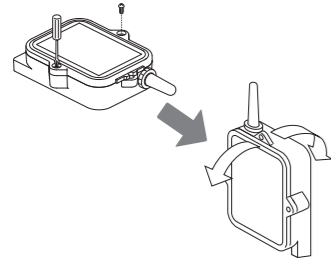

● Make sure that + and - are correct.

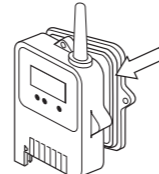

- If dirt or scratches are present on the rubber packing, water resistance will be reduced.
- Be sure to fasten the cover tightly.

※ If nothing appears on the LCD Display, please follow the above instructions again.

### ◆ Connect the Input Cable

Confirm that the sensor is properly connected by inserting it until you hear a clicking sound.

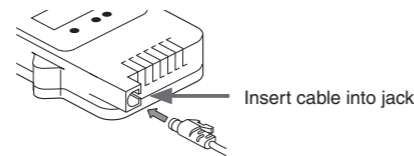

Insert cable into jack

### ◆ Upon insertion of the batteries, measuring and recording will automatically begin at the factory set default recording settings, or if replacing the batteries the settings will return to the most recent recording settings.

The default settings are: Recording Mode: Endless / Recording Interval: 1 minutes / Recording Start: Immediate Start (Measurement and recording will automatically begin in Voltage Measurement Mode.)

## Changing the Battery

Note:

- Once the battery indicator [ ] appears, replace the old battery with a new one as soon as possible.
- After removing the old battery, all recorded data will be lost if a new battery is not inserted within 1 minute. Make sure to complete the battery change within 1 minute.
- If the battery direction is incorrect (+/-) and a short occurs, all recorded data saved in the main unit will be lost.
- Please store the LS14250 batteries in a temperature of less than 20°C .
- When using an LS14250 battery, the battery indicator [ ] on the main unit display may not soon disappear, even if you have used a new battery. This is due to the nature of the battery and the time it will take for the indicator to disappear will increase with the time that the battery has been in storage. If a battery has been in storage for about one year, it will take about 10 minutes for the indicator to disappear. During this time, if you try to collect Remote Unit Info via the RTR-57U it will respond that the battery level is too low.

1. When battery power becomes low, the battery indicator ( ) will appear in the LCD display.

- If you change the battery at this time, recording will continue uninterrupted and the downloading of recorded data is possible.



If you do not change.  
Recording: OK  
Wireless Communication: OK  
Data Download: OK

2. If you do not change the battery and continue using the unit, the temperature display will intermittently display [bAtt]. Please change the battery at once.

- If at this time a new battery is placed in the unit, recording will continue and downloading of saved data can be done.



If you do not change.  
Recording: OK  
Wireless Communication: NO  
Data Download: NO

3. Check the rubber packing for any cuts or scratches and replace the cover as it was when opened.

- In order to save all recorded data during [SLP], all recording and other normal functions will be disabled. If you change the battery at this time all recorded data can still be downloaded.



If you do not change.  
Recording: NO  
Wireless Communication: NO  
Data Download: NO

- If, after changing the battery, you wish to start recording again, please make new recording start settings via computer or via the RTR-57U unit.

Note:

By starting a new recording session, all previously recorded data will be erased. Make sure to download any data you need before you start a new recording session.

4. If you do not change the battery even under conditions in 3 above, the display will go blank.

- All of the recorded data will be erased. If at this time a new battery is placed in the unit, [CHEC] will appear on the display after which recording will begin again using the previously set recording conditions.



## About the LCD Display

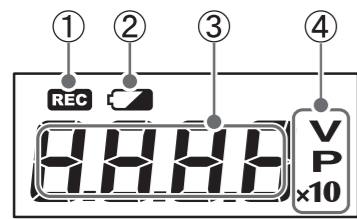

- ① LIT UP: displayed during recording or when FULL of data.  
BLINKING: displayed when waiting for a programmed recording to start
- ② Low Battery Life Warning Indicator: displayed when time to change the battery.
- ③ Current Reading or Operation Message displayed
- ④ Shows Unit of Current Reading being displayed

V : Voltage  
P : Percent  
Only displayed when measuring soil moisture.

x10 : when the number of pulse readings is above 10,000  
When measuring pulse there is no unit

Note:  
Use in cold environments may cause the display to be difficult to read; this is not a malfunction.



#### ● Check

This is displayed under the following conditions: after purchasing and putting in the batteries for the first time, if the battery terminals +/- were mistaken and a short occurred, or if the batteries are replaced after having been taken out for a long period. If this is displayed all data that had been stored in the main unit has been erased.



#### ● Full Memory

If recording under the ONE TIME MODE, when the data readings reach the upper limit of 8,000 readings, recording will stop and this will be displayed intermittently with the current temperature.



#### ● Wireless Transmission

This will be displayed when transmitting data to an RTR-57U unit via wireless communication.



#### ● Over Measurement Range

(only for Voltage Measurement)

Display will blink if measurement is below 0 or above 6.5 V



#### ● Over 10,000 Pulse Count Readings Display

On tenth of readings will be displayed with a x10.

#### About the Pulse Measurement Display

The reading shown on the pulse measurement display shows the number of total pulse counts for the recording interval set at the recording start and changes every one sixtieth of the time of the set recording interval.

For example: If the recording interval is set at 30 minutes, the display will show the total number of pulse counts for the previous thirty minutes; changing at a rate of every thirty seconds. (If the interval is set at 1 minute or less, the measurement count and the display will change every second.)



#### ● Signal Level at time of Event Recording

If the current signal level is high, HI will be displayed.



#### ● Signal Level at time of Event Recording

If the current signal level is low, Lo will be displayed.

## Soil Moisture Measurement

It is possible to measure soil moisture using Decagon Devices Inc, Soil Moisture Sensor ECHO Probes (EC-10, EC-20). The RVR-52A has a built-in excitation voltage (2.5V) for the ECHO probe that allows for easy direct connection. The output from the ECHO probe is converted directly into moisture volume content by percentage (%) and displayed as such. Moreover, by using the adjustment function in the accompanying software [T&D Recorder for Windows (US)] you can achieve even more accurate readings.

Note:

T&D Corporation does not handle or sell the Soil Moisture Sensors ECHO Probe (EC-10, EC-20). All inquiries and questions concerning sales of and the operational specifications of the sensors should be made to Decagon Devices Inc.

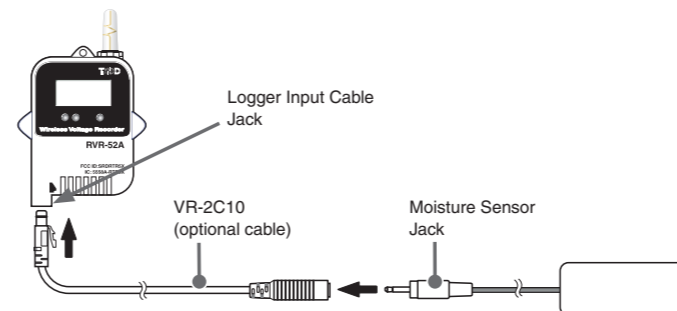

1. Connect the Input Cable (VR-2C10).  
Connect the VR-2C10 (optional cable) to the logger's input cable jack, making sure to insert until you hear a clicking sound.
2. Connect the Moisture Sensor to the VR-2C10.  
Connect the Moisture Sensor jack to the VR-2C10 terminal, making sure to insert until you hear a clicking sound
3. Make Necessary Mode Settings and Start Recording.  
In the accompanying software [T&D Recorder for Windows(US)], under [Measuring Mode] set to [Moisture] and start recording.

## Connection Specifications

### Soil Moisture Measurement Mode

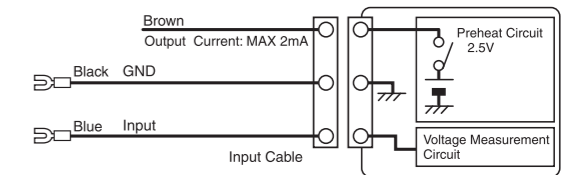

### Voltage Measurement Mode

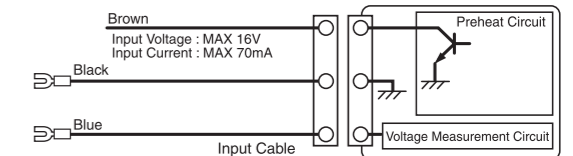

### Pulse / Event Measurement Mode

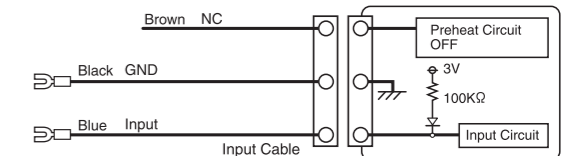

Pulse Signal (Max. 0~30Vp-p)

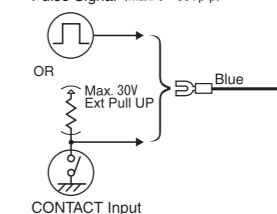

CONTACT Input